

### 3 Product Description

The safety-related **F30 03** controller is a compact system in a metal housing with 20 digital inputs and 8 digital outputs.

The controller is available in various model variants, see Table 3.

The configuration is performed using SILworX, see Chapter 4.3.

The device is suitable for sequence of events recording (SOE), see Chapter 4.2. The device supports multitasking and reload. For more details, refer to the system manual compact systems (HI 800 141 E).

**i**

A licence is required to use the events recording, the multitasking and the reload features.

The device is TÜV-certified for safety-related applications up to SIL 3 (IEC 61508, IEC 61511 and IEC 62061), Cat. 4 and PL e (EN ISO 13849-1) and SIL 4 (EN 50126, EN 50128 and EN 50129).

Further safety standards, application standards and test standards are specified in the certificates available on the HIMA website.

#### 3.1 Safety Function

The controller is equipped with safety-related digital inputs and outputs.

##### 3.1.1 Safety-Related Digital Inputs

The controller is equipped with 20 digital inputs. The state (HIGH, LOW) of each input is signaled by an individual LED.

Mechanical contacts without own power supply or signal power source can be connected to the inputs.

Potential-free mechanical contacts without own power supply are fed via an internal short-circuit-proof 24 V power source (LS+). Each of them supply a group of 4 mechanical contacts. Figure 1 shows how the connection is performed.

With signal voltage sources, the corresponding ground must be connected to the input (L-), see Figure 1.

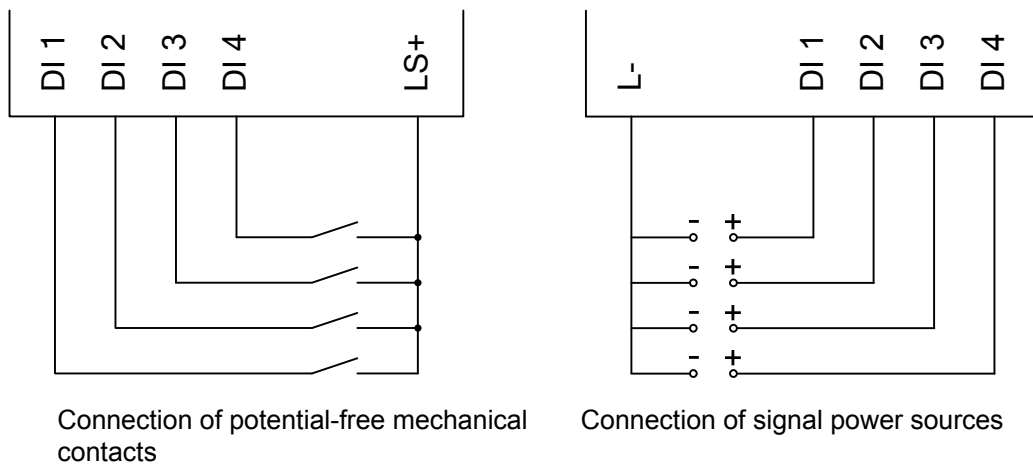

Figure 1: Connections to Safety-Related Digital Inputs

For the external wiring and the connection of sensors, apply the de-energized-to-trip principle. Thus, if a fault occurs, the input signals adopt a de-energized, safe state (low level).

If an external wire is not monitored, an open-circuit is considered as safe low level.

### 3.1.1.1 Reaction in the Event of a Fault

If the device detects a fault on a digital input, the user program processes a low level in accordance with the de-energized to trip principle.

The device activates the *FAULT* LED.

In addition to the channel signal value, the user program must also consider the corresponding error code.

The error code allows the user to configure additional fault reactions in the user program.

### 3.1.1.2 Line Control

Line control is used to detect short-circuits or open-circuits and can be configured for the F30 system, e.g., on EMERGENCY STOP inputs complying with Cat. 4 and PL e in accordance with EN ISO 13849-1.

To this end, connect the digital outputs DO 1 through DO 8 of the system to the digital inputs DI of the same system as follows:

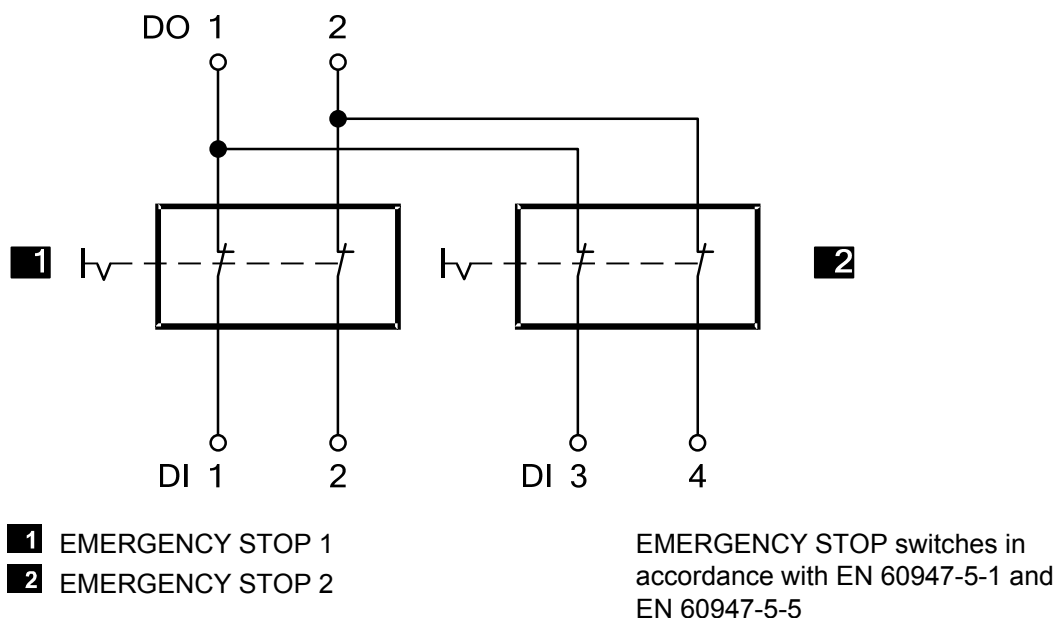

Figure 2: Line Control

The controller pulses the digital outputs to detect the line short-circuits and open-circuits on the lines connected to the digital inputs. To do so, configure the *Value [BOOL]* -> system variable in SILworX. The variables for the pulsed outputs must begin with channel 1 and reside in direct sequence, one after the other.

If the following faults occur, the *FAULT* LED located on the front plate of the controller blinks, the inputs are set to low level and an (evaluable) error code is created:

- Cross-circuit between two parallel wires.
- Invalid connections of two lines (e.g., DO 2 to DI 3),
- Earth fault on one wire (with earthed ground only).
- Open-circuit or open contacts, i.e., including when one of the two EMERGENCY STOP switches mentioned above has been engaged, the *FAULT* LED blinks and the error code is created.

### 3.6 Certified HIMatrix F30 03

HIMatrix F30	
CE	EMC
TÜV	IEC 61508 1-7:2010 up to SIL 3 IEC 61511:2004 EN ISO 13849-1:2008 IEC 62061:2005 EN 50156-1:2004 EN 298:2003 EN 230:2005
PROFIBUS Nutzerorganisation (PNO)	Test Specification for PROFIBUS DP Slave, Version 3.0 November 2005
TÜV CENELEC	Railway applications EN 50126: 1999 up to SIL 4 EN 50128: 2001 up to SIL 4 EN 50129: 2003 up to SIL 4

Table 16: Certificates

Further safety standards and application standards are specified in the certificate. The certificate and the EC type test certificate are available on the HIMA website at [www.hima.com](http://www.hima.com).